

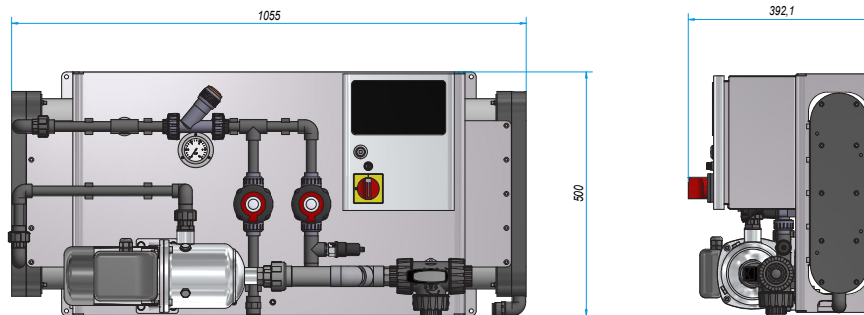

HP MWT

HP MWT is the brand new marina water treatment system using reverse osmosis membranes, that bring TDS and total hardness to very low levels, protecting all systems that use fresh water from limescale, and allowing a **no-spots effects** on all the surfaces. HP MWT systems are designed to provide water with very low TDS and hardness to safeguard the systems, saving on maintenance of boilers, pipes, pumps, toilets, washing machines, dishwashers etc. **HP MWT is already interfaced with Part-NET Interface.**



Model	
HP MWT	
Kit prefilter CA10"	
HP CA10" activated carbon cartridge	
Technical specifications	
Max pressure bar	5
Min pressure bar	2
Max temperature °C	45
Total Weight Kg	40
Dimensions mm (WxHxD)	1055 x 500 x 392



Since 1995 at the service of the water industry



Registered to:
ISO 9001
ISO 14001
OHSAS 18001

